

Lecture #2
Oscilloscopes 2
Comparators
EE 211
Clarkson University

Scope 2 topics

- Dual Trace Operation
- X-Y plots
- Phase angle measurement
- Equipment:
 - decade capacitor
 - 10k Ω decade resistor

- Decade resistor.
- Note the 3 studs— red and black connect to the resistances.
- Check with an ohmmeter.
- The silver stud is case ground, it is there for safety and for shielding.



Voltage Divider RC circuit used in the lab

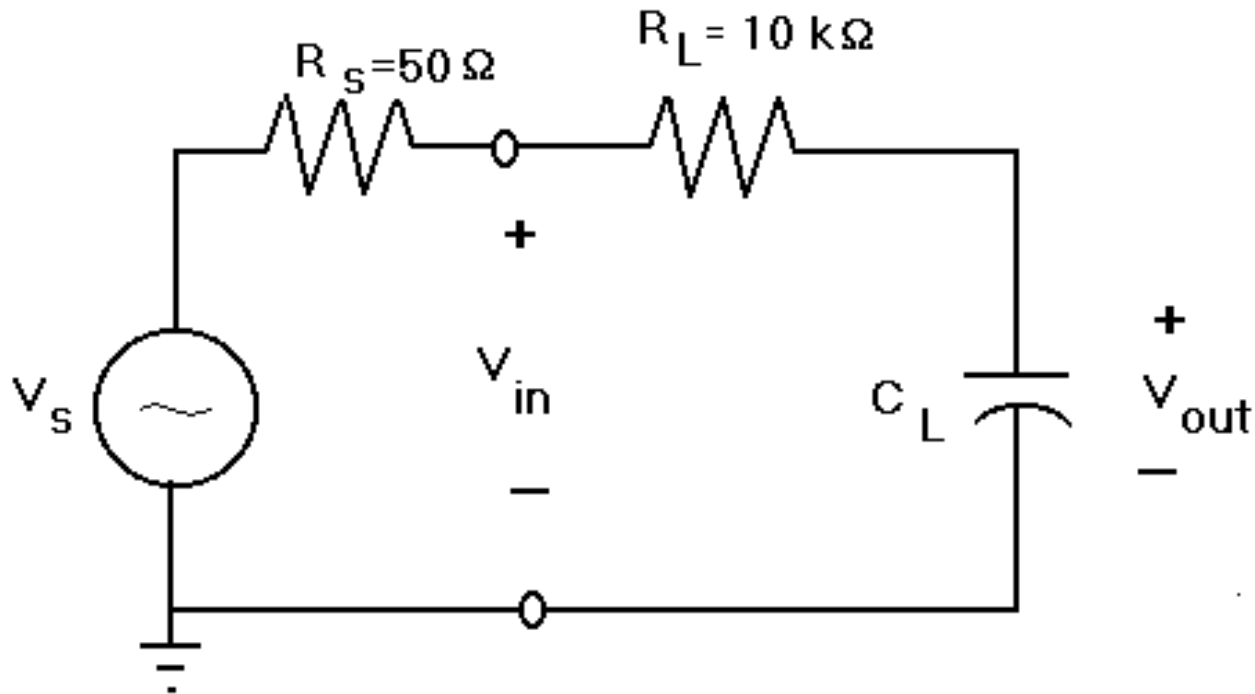

Figure 1.

Analysis of RL circuit

$$Z_{CL} = -jX_{CL} = \frac{1}{j\omega C_L}$$

$$V_{out} = V_{in} \frac{Z_{CL}}{Z_{CL} + R_L}$$

Two Channel Oscilloscope Operation

- Phase Angles
- Mathematical Options
- Differential Voltage Measurement
- X-Y plots

Phase Angle Measurement (1)

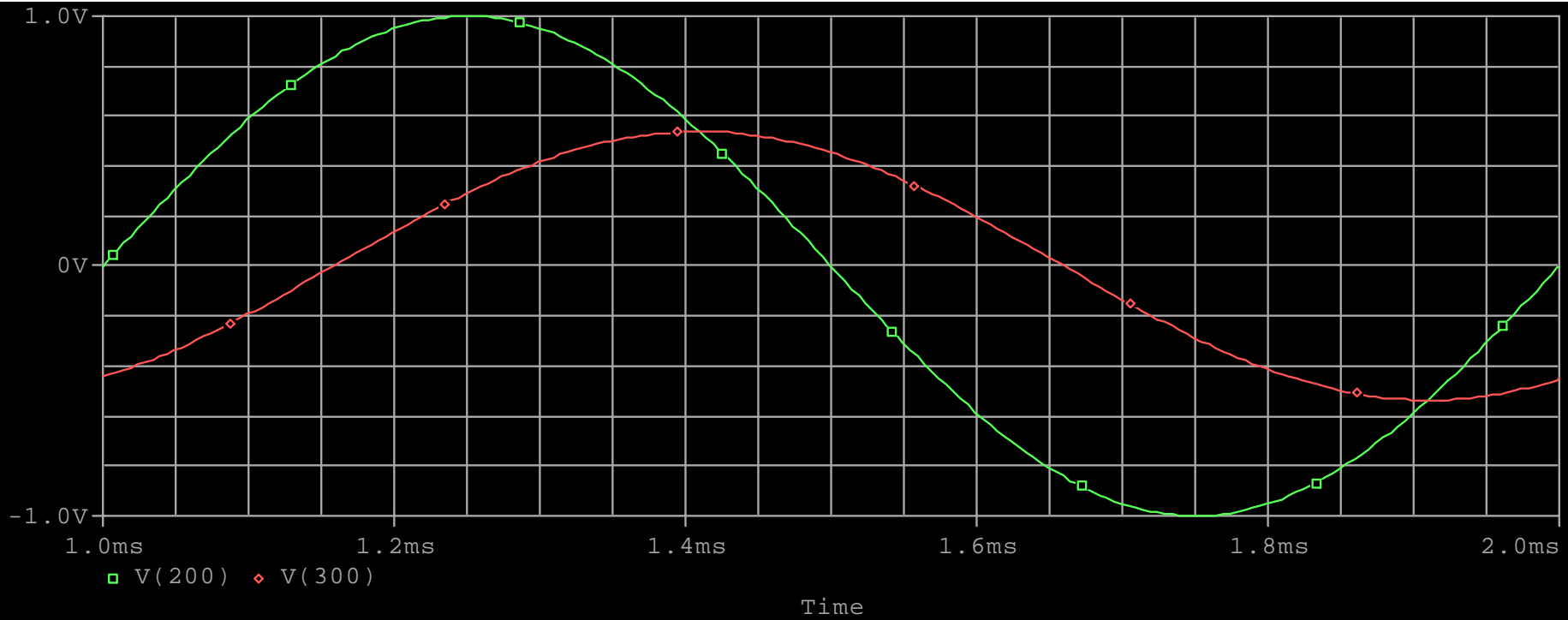

Phase Angle Measurements (2)

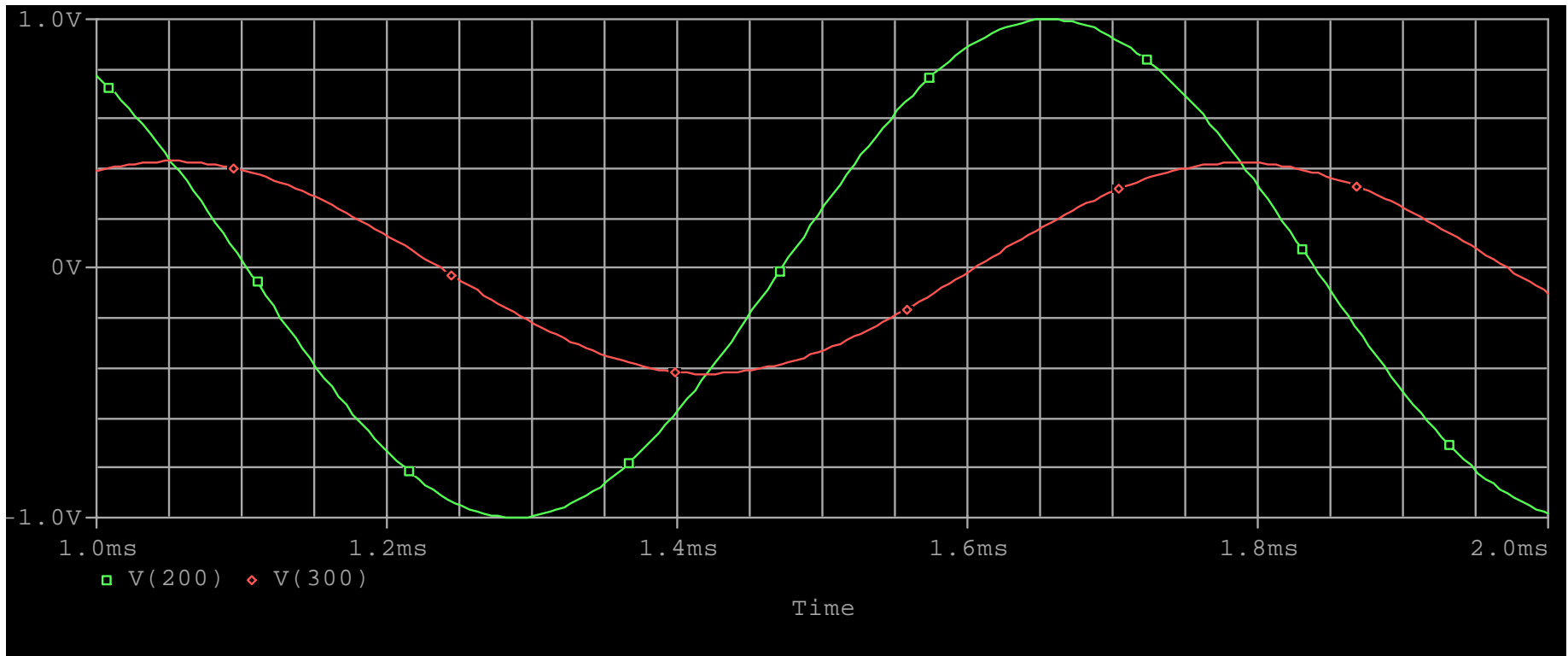

Lissajous Figures ($\theta = \text{Arcsin}(A/B)$)

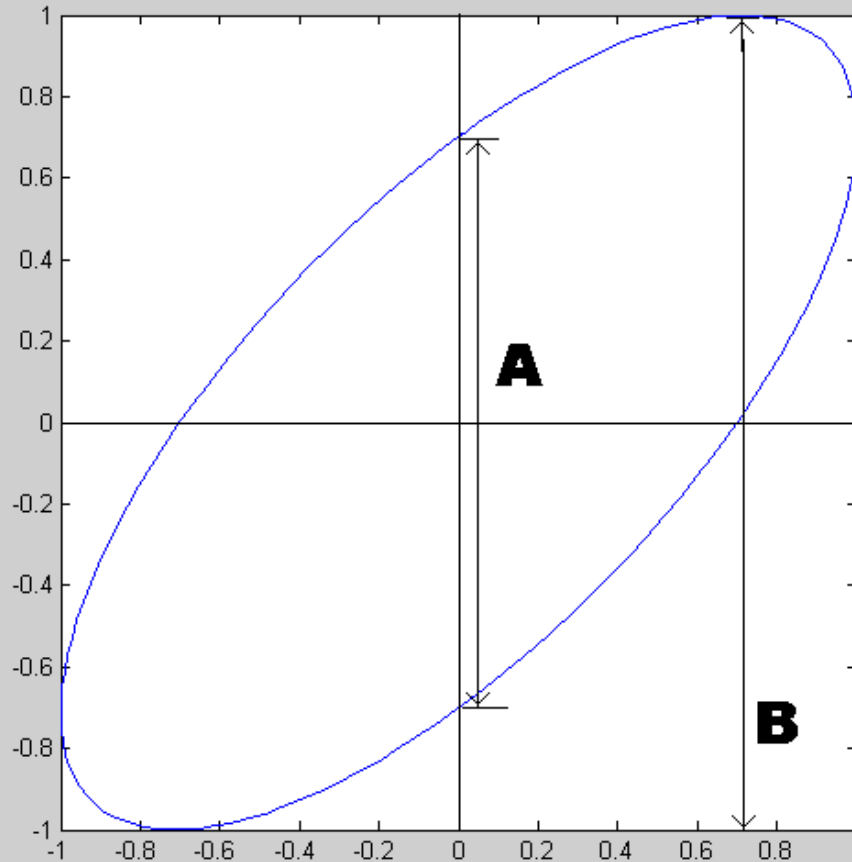

Before Lab

- Calculate the value of C_L for Step 2.
- Calculate the values of R_L for the 4 angles given in Step 18.
- Review the oscilloscope material referenced on the course web site.
- (optional) Review Lissajous diagrams on the web.

Lab 4. Comparators

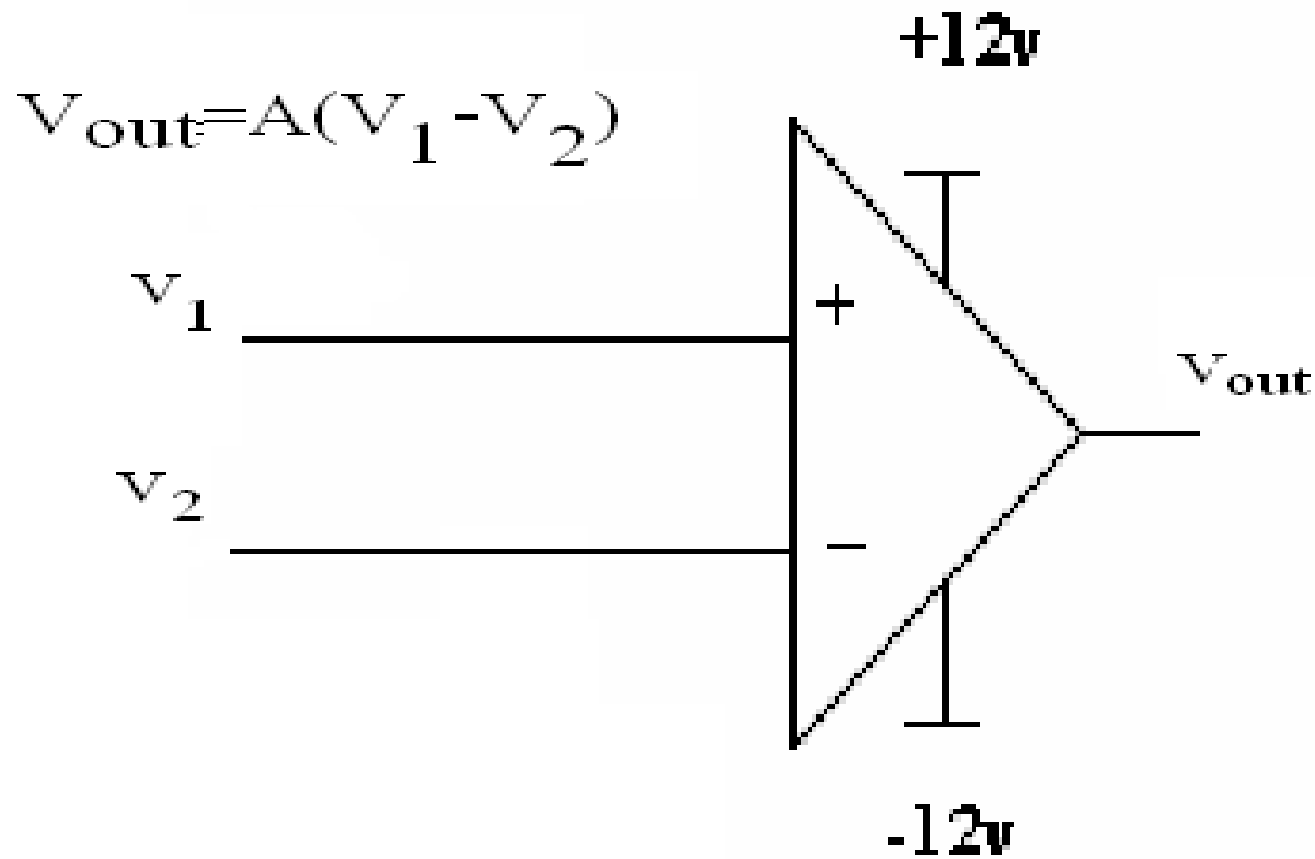

potentiometer

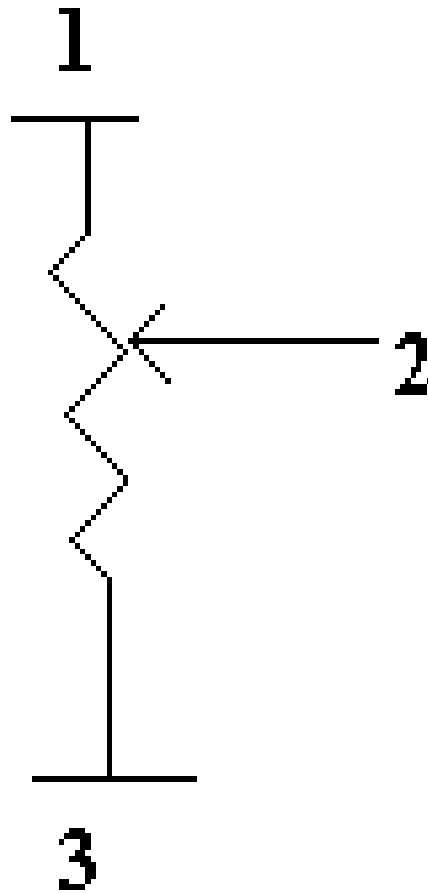

Determine pins with an ohmmeter

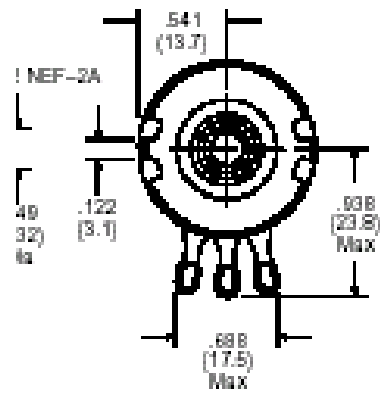
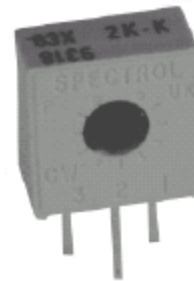
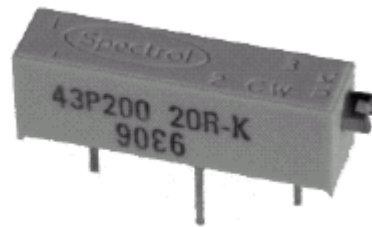

L = Shaft Length (See Table)



8-DIP

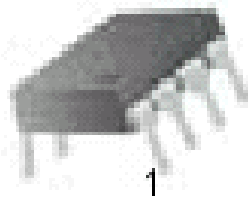

Dual-In-Line or S.O. Package

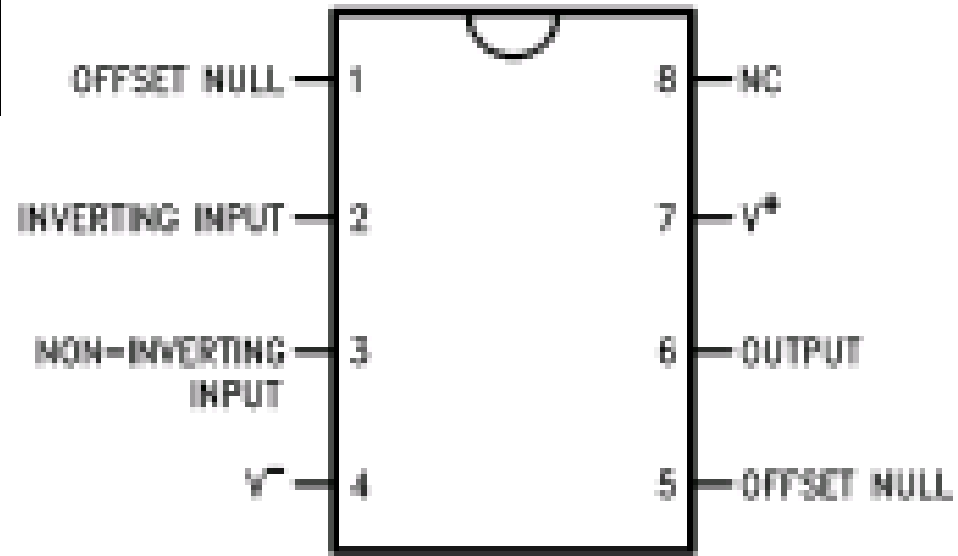

DIS00924-1-3

Order Number LM741J, LM741J/883, LM741CN
See NS Package Number J08A, M08A or N08E

Circuit #1

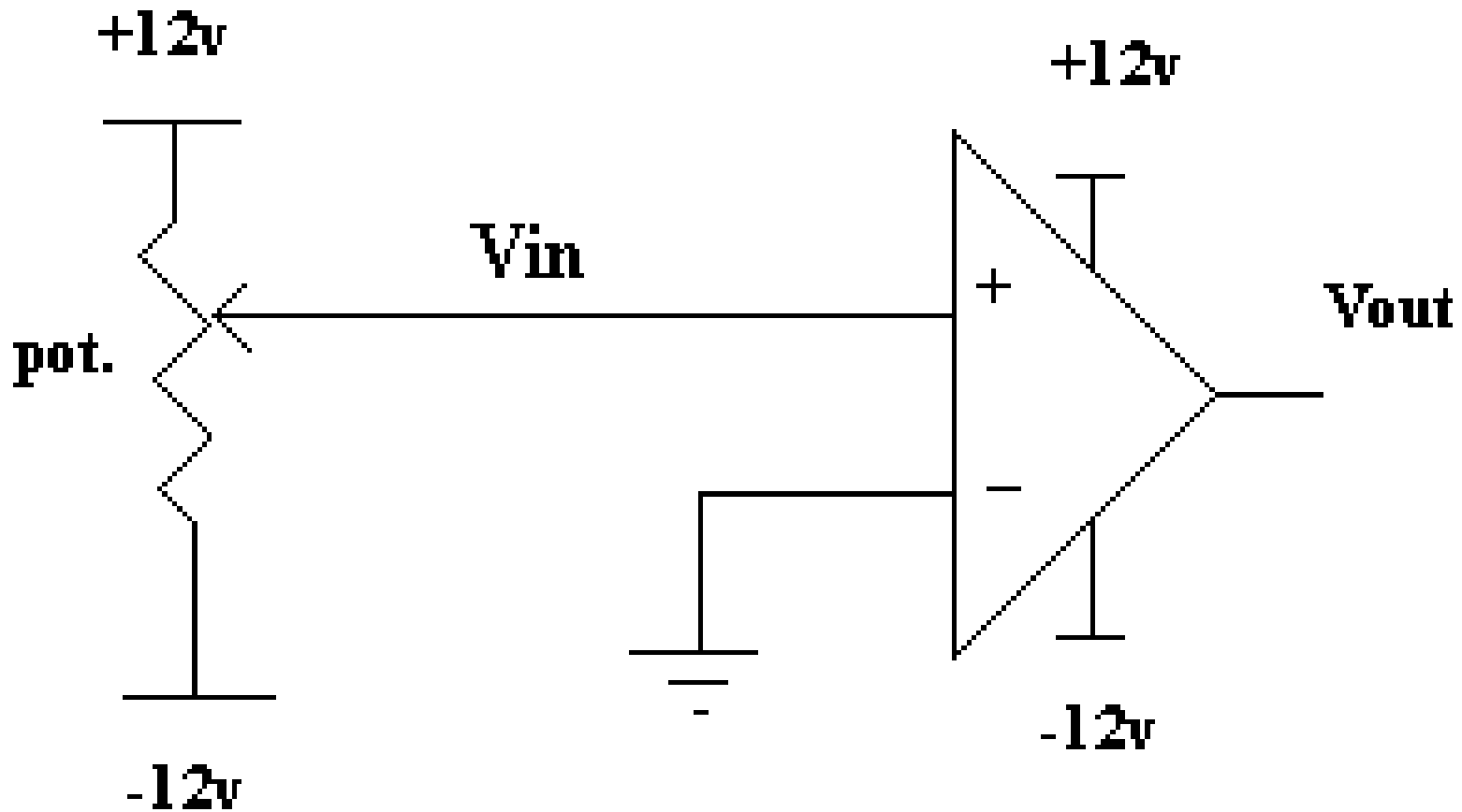

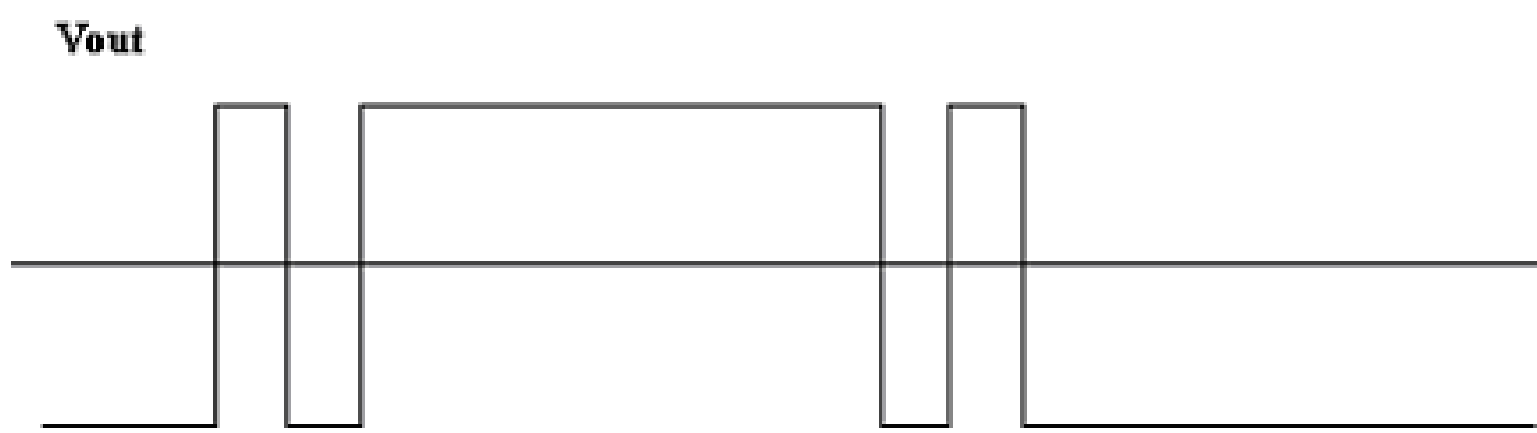
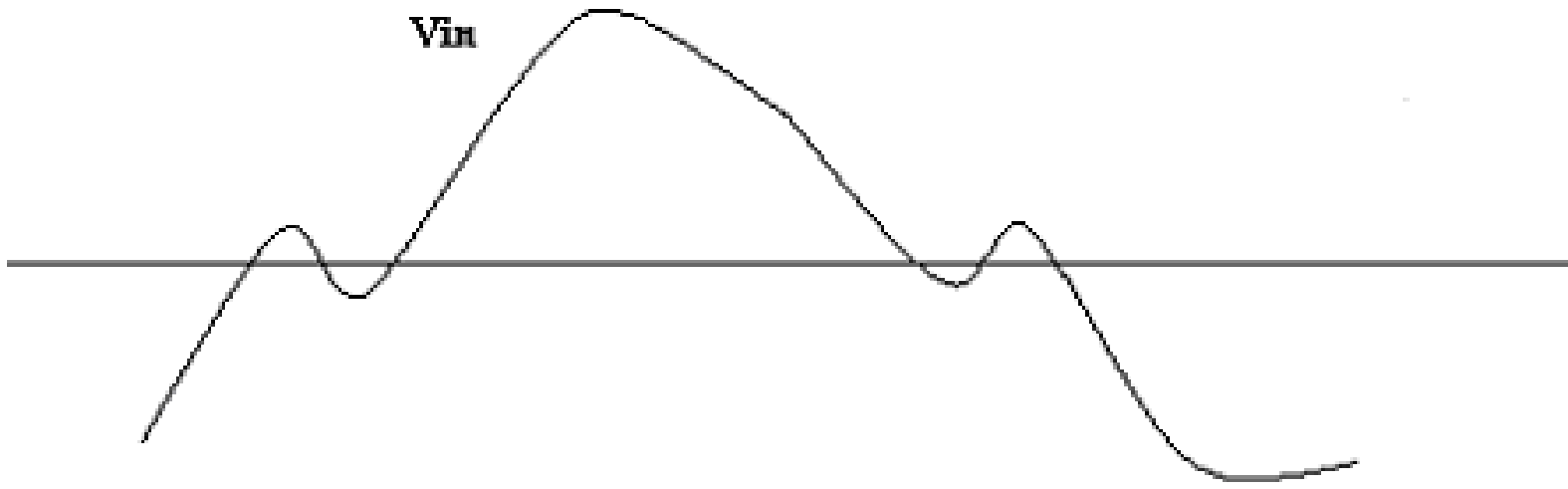

Protoboards

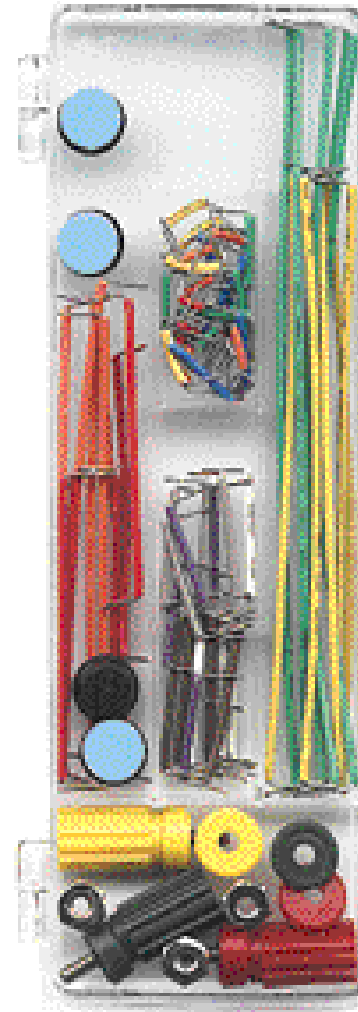
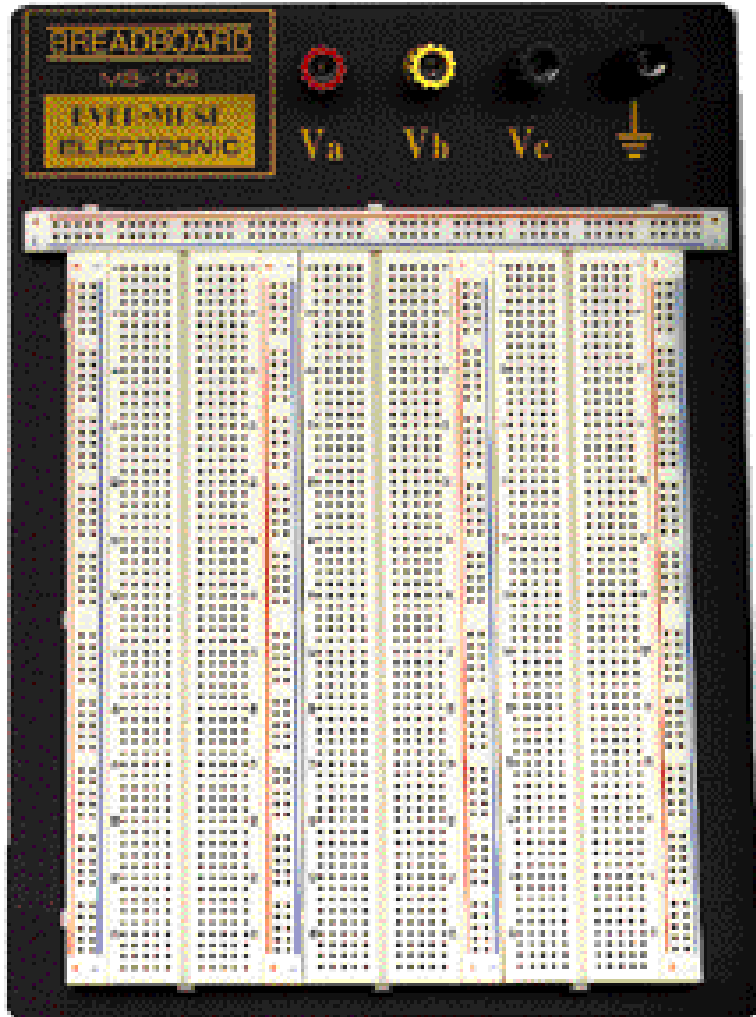

Op Amp troubleshooting guide

1. Check power supply voltage to the op amp— with voltmeter
2. Check V_{out} on the scope—make sure you are on dc coupling. Keep this trace on the screen
3. Check the non-inverting and inverting inputs— are they the same (should they be the same?)

Op Amp troubleshooting (#2)

5. If the output is on one of the rails, ground both input terminals, the output should go to zero
6. Should the op amp be in the linear region, but is not? Check your circuit—particularly the feedback circuit.
7. No output at all? Set it up as a comparator, and recheck output.

Troubleshooting Tips

- Measure voltages– visual inspections are not reliable.
- Think of complex circuits as a set of subcircuits, and check each subcircuit individually.
- Don't ignore the ground bus--

What Happens?

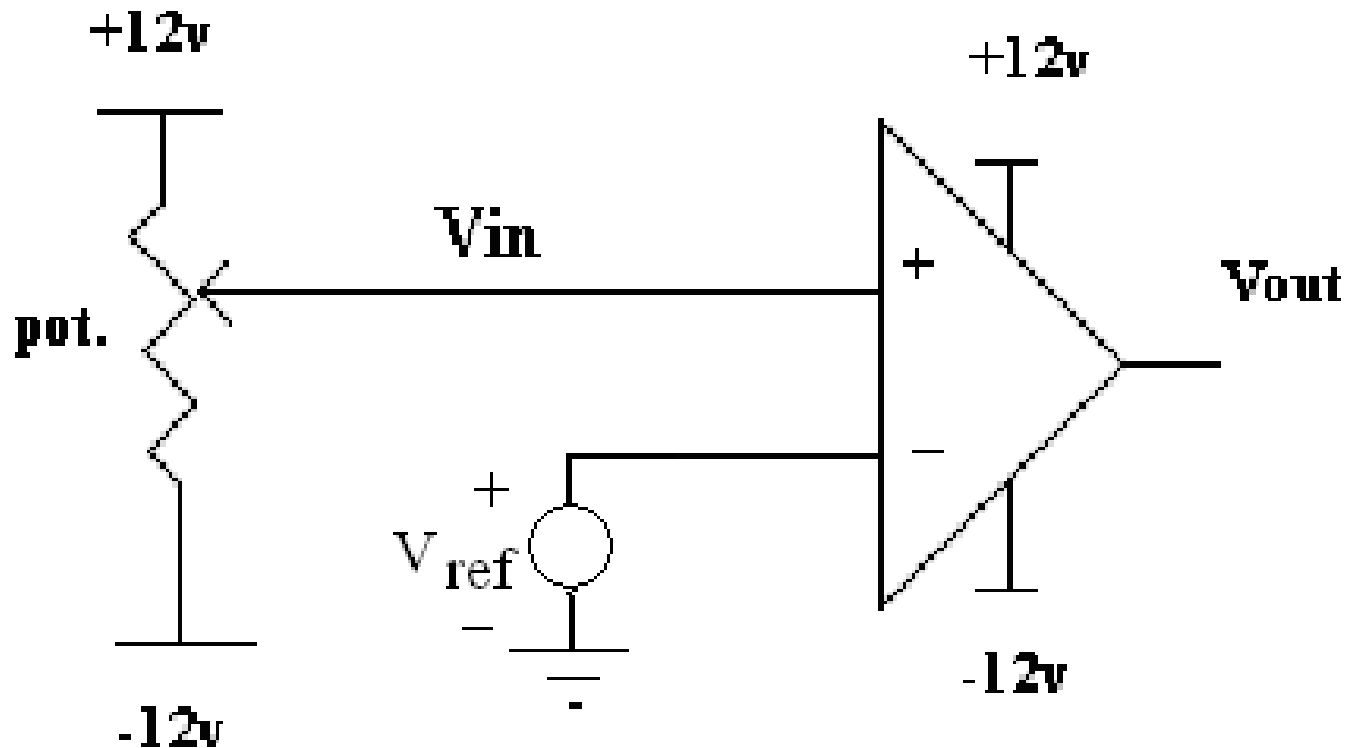

What Happens?

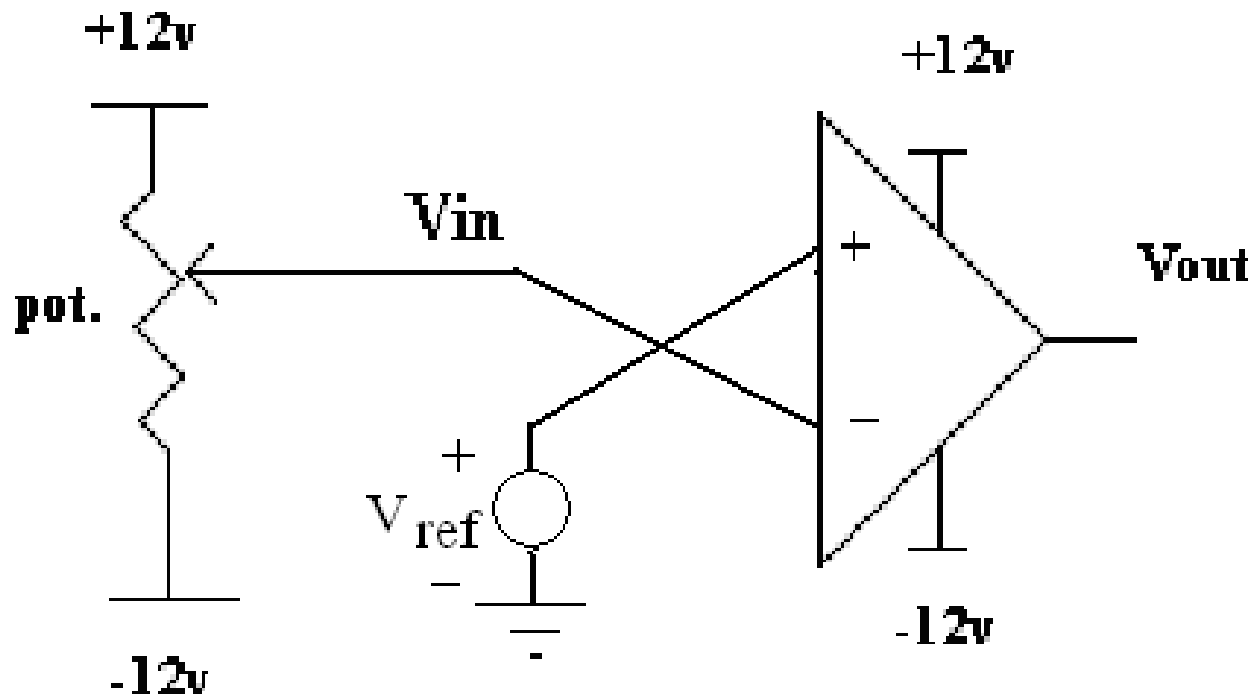

Schmitt Trigger circuit

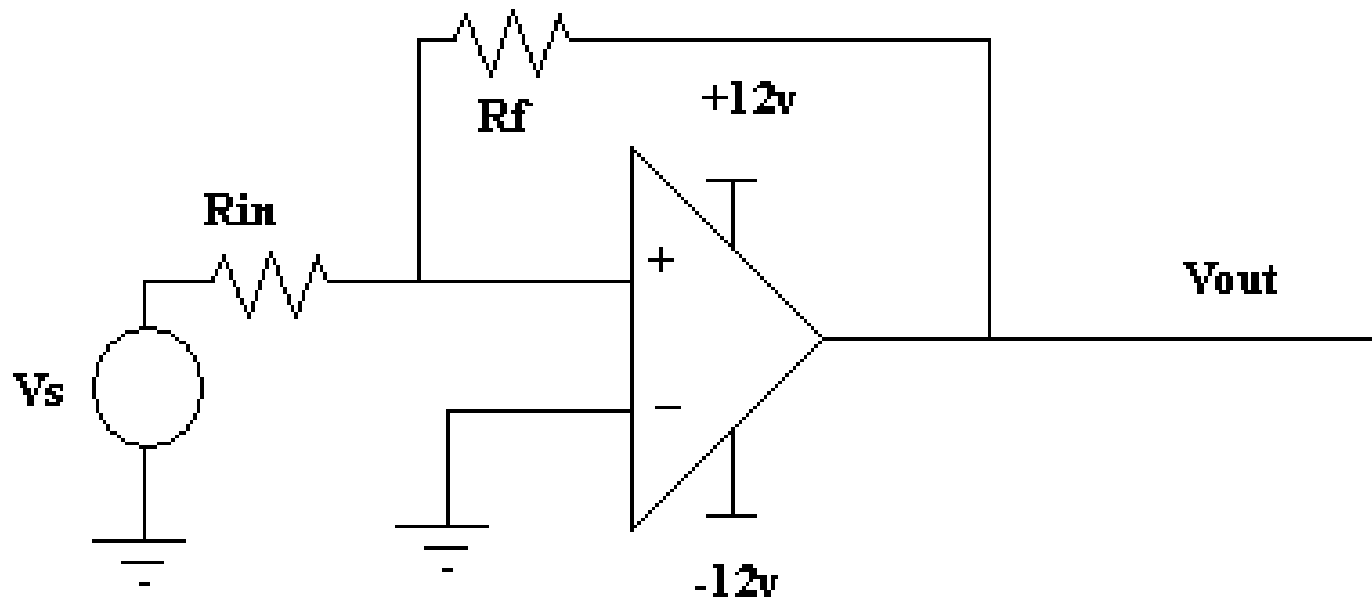

Schmitt trigger equations

$$V_{+} = (V_{out} - V_s) \frac{R_{in}}{R_f + R_{in}} + V_s$$

$$= V_{out} \frac{R_{in}}{R_f + R_{in}} + V_s \frac{R_f}{R_f + R_{in}}$$

hysteresis term

scaling term

Example

- If V_{out} is either +12v or -12v
- and $R_f = 11 * R_{in}$
- Then the hysteresis term will be ± 1 volt
- (Note: scaling does not matter when the inverting input is set to zero)

Schmitt Trigger w/noise



Schmitt Trig.-Vout vs. Vin

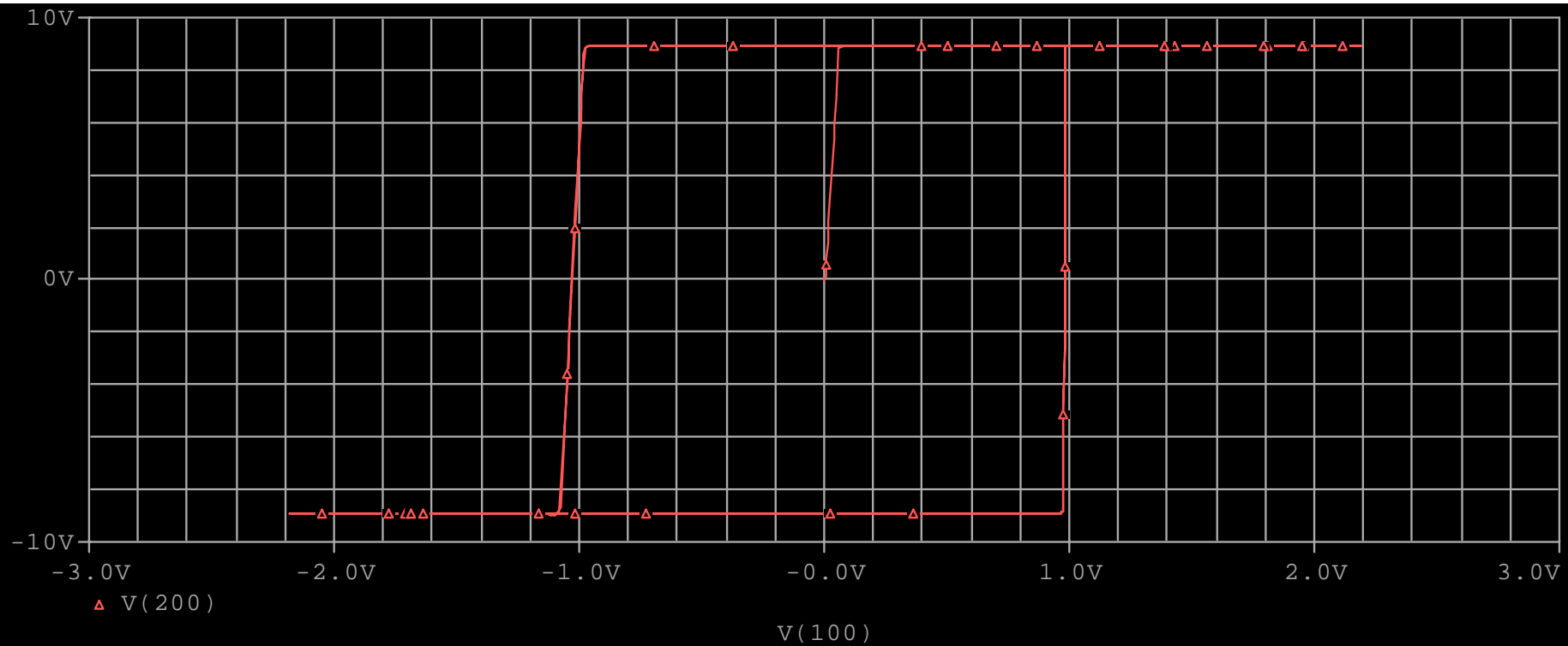

Writing Assignment

- Review LABORATORY REPORT STYLE GUIDE on the course web site
- The second writing assignment will be to write a section presenting data from Step G of the comparator lab, on Schmitt triggers.
- Present a table showing the comparison between predicted and measured deadbands of the Schmitt triggers you build.

Assignment

- Include a single paragraph discussing the results that are presented in the table.
- Do not discuss Schmitt trigger theory or your lab procedure.
- Do discuss the quality of your results—comment on the accuracy or lack of accuracy.

Details

- Due date 3 working days, during your next lab period.
- This is one subsection of the main body of a report describing this whole lab.
- Include an analysis of your results

PreLab Requirements

- O'scopes 2
 - Calculate the RC network resistor values
 - Review the Lissajous data
- Comparators
 - Read the Op amp spec sheet, review the troubleshooting guide.