

EE 447 VLSI Design

Lecture 5: Wires

Outline

- Introduction
- Wire Resistance
- Wire Capacitance
- Wire RC Delay
- Crosstalk
- Wire Engineering
- Repeaters

Introduction

- Chips are mostly made of wires called *interconnect*
 - In stick diagram, wires set size
 - Transistors are little things under the wires
 - Many layers of wires
- Wires are as important as transistors
 - Speed
 - Power
 - Noise
- Alternating layers run orthogonally

Wire Geometry

- Pitch = $w + s$
- Aspect ratio: $AR = t/w$
 - Old processes had $AR \ll 1$
 - Modern processes have $AR \approx 2$
 - Pack in many skinny wires

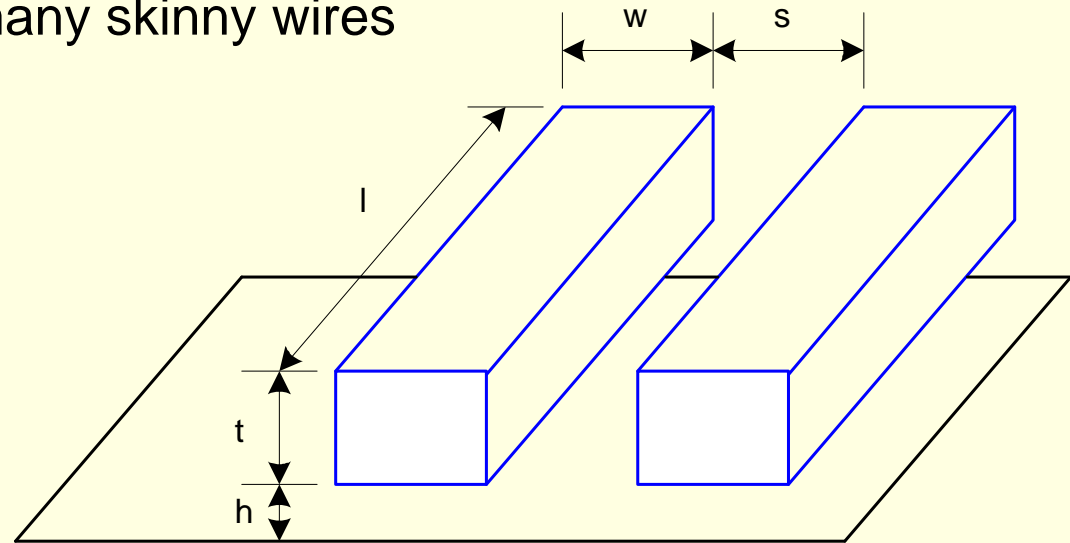

Layer Stack

- AMI 0.6 μm process has 3 metal layers
- Modern processes use 6-10+ metal layers

- Example:

Intel 180 nm process

- M1: thin, narrow ($< 3\lambda$)
 - High density cells
- M2-M4: thicker
 - For longer wires
- M5-M6: thickest
 - For V_{DD} , GND, clk

Layer	T (nm)	W (nm)	S (nm)	AR	
6	1720	860	860	2.0	
	1000				
5	1600	800	800	2.0	
	1000				
4	1080	540	540	2.0	
	700				
3	700	320	320	2.2	
	700				
2	700	320	320	2.2	
	700				
1	480	250	250	1.9	
	800				

Substrate

Wire Resistance

- $\rho = \text{resistivity } (\Omega \cdot \text{m})$

$R =$

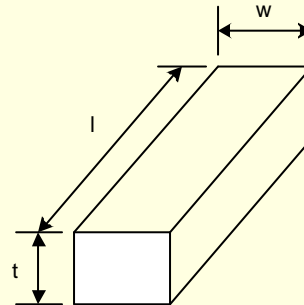

Wire Resistance

- $\rho = \text{resistivity } (\Omega \cdot \text{m})$

$$R = \frac{\rho l}{t w}$$

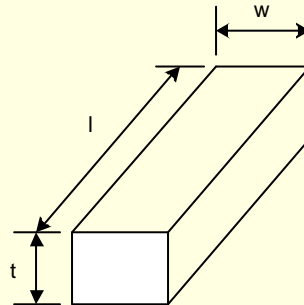

Wire Resistance

- $\rho = \text{resistivity } (\Omega \cdot \text{m})$

$$R = \frac{\rho}{t} \frac{l}{w} = R_{\square} \frac{l}{w}$$

- $R_{\square} = \text{sheet resistance } (\Omega/\square)$

- \square is a dimensionless unit(!)

- Count number of squares

- $R = R_{\square} * (\# \text{ of squares})$

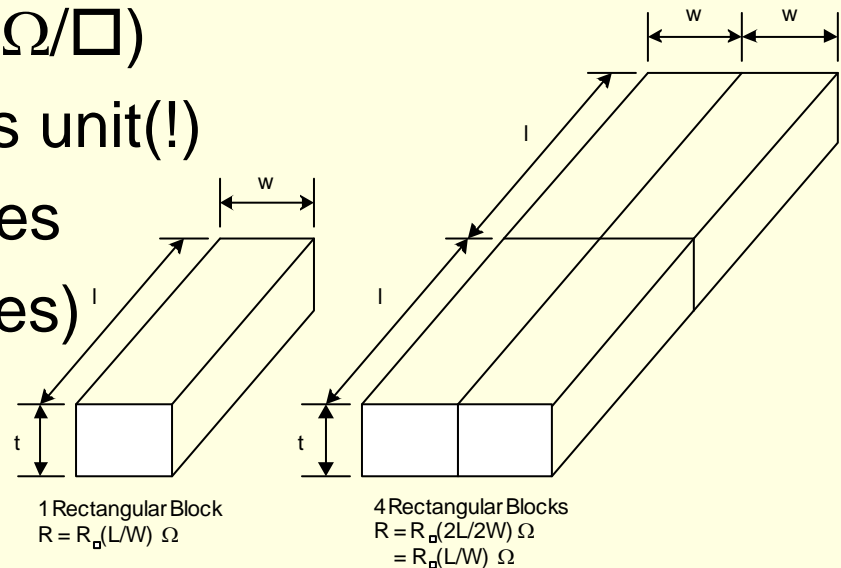

Choice of Metals

- Until 180 nm generation, most wires were aluminum
- Modern processes often use copper
 - Cu atoms diffuse into silicon and damage FETs
 - Must be surrounded by a diffusion barrier

Metal	Bulk resistivity ($\mu\Omega\cdot\text{cm}$)
Silver (Ag)	1.6
Copper (Cu)	1.7
Gold (Au)	2.2
Aluminum (Al)	2.8
Tungsten (W)	5.3
Molybdenum (Mo)	5.3

Sheet Resistance

- Typical sheet resistances in 180 nm process

Layer	Sheet Resistance (Ω/\square)
Diffusion (silicided)	3-10
Diffusion (no silicide)	50-200
Polysilicon (silicided)	3-10
Polysilicon (no silicide)	50-400
Metal1	0.08
Metal2	0.05
Metal3	0.05
Metal4	0.03
Metal5	0.02
Metal6	0.02

Contacts Resistance

- Contacts and vias also have 2-20 Ω
- Use many contacts for lower R
 - Many small contacts for current crowding around periphery



Wire Capacitance

- Wire has capacitance per unit length
 - To neighbors
 - To layers above and below
- $C_{\text{total}} = C_{\text{top}} + C_{\text{bot}} + 2C_{\text{adj}}$

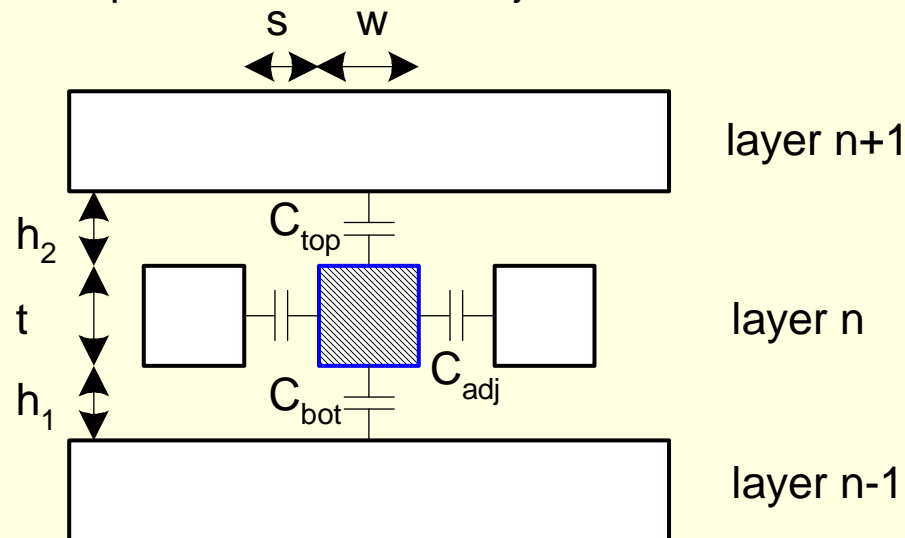

Capacitance Trends

- Parallel plate equation: $C = \epsilon A/d$
 - Wires are not parallel plates, but obey trends
 - Increasing area (W , t) increases capacitance
 - Increasing distance (s , h) decreases capacitance
- Dielectric constant
 - $\epsilon = k\epsilon_0$
- $\epsilon_0 = 8.85 \times 10^{-14}$ F/cm
- $k = 3.9$ for SiO_2
- Processes are starting to use low- k dielectrics
 - $k \approx 3$ (or less) as dielectrics use air pockets

M2 Capacitance Data

- Typical wires have $\sim 0.2 \text{ fF}/\mu\text{m}$
 - Compare to $2 \text{ fF}/\mu\text{m}$ for gate capacitance

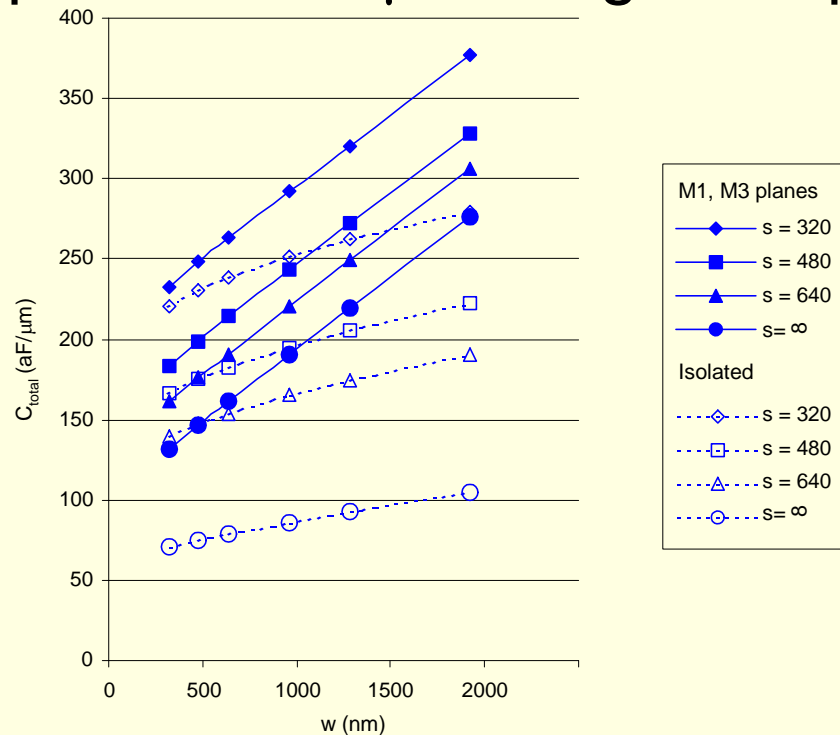

Diffusion & Polysilicon

- Diffusion capacitance is very high (about 2 fF/ μm)
 - Comparable to gate capacitance
 - Diffusion also has high resistance
 - Avoid using diffusion *runners* for wires!
- Polysilicon has lower C but high R
 - Use for transistor gates
 - Occasionally for very short wires between gates

Lumped Element Models

- Wires are a distributed system
 - Approximate with lumped element models

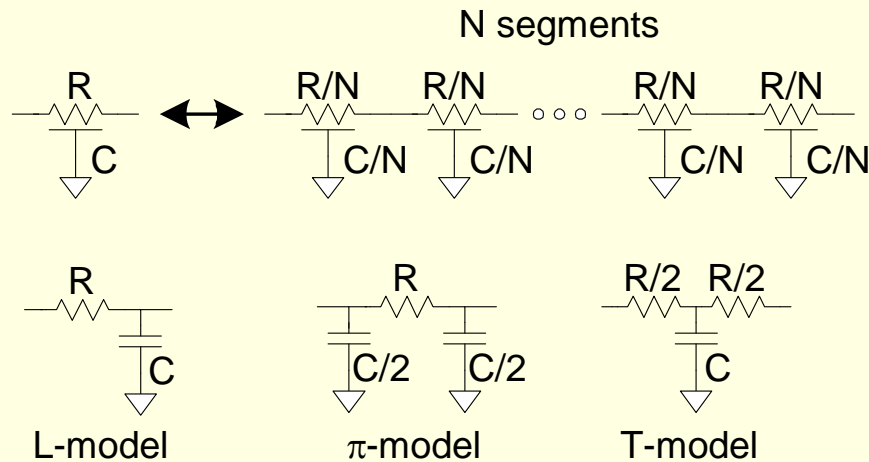

- 3-segment π -model is accurate to 3% in simulation
- L-model needs 100 segments for same accuracy!
- Use single segment π -model for Elmore delay

Example

- Metal2 wire in 180 nm process
 - 5 mm long
 - 0.32 μm wide
- Construct a 3-segment π -model
 - $R_{\square} =$
 - $C_{\text{permicron}} =$

Example

- Metal2 wire in 180 nm process
 - 5 mm long
 - 0.32 μm wide
- Construct a 3-segment π -model
 - $R_{\square} = 0.05 \Omega/\square$ $\Rightarrow R = 781 \Omega$
 - $C_{\text{permicron}} = 0.2 \text{ fF}/\mu\text{m}$ $\Rightarrow C = 1 \text{ pF}$

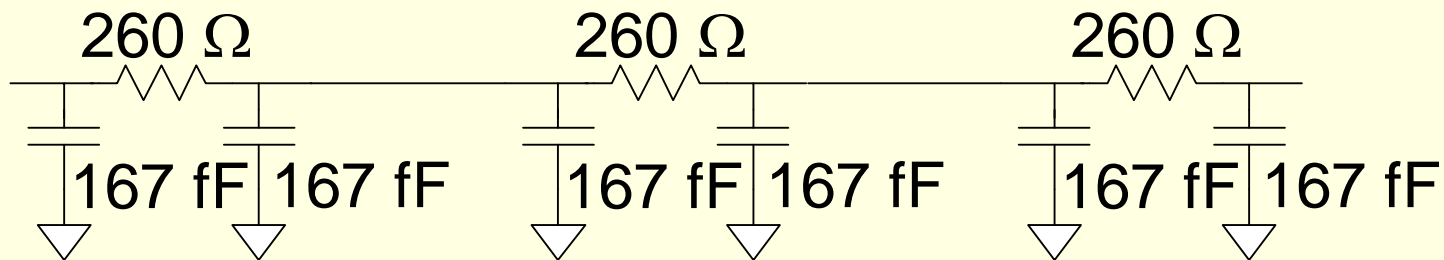

Wire RC Delay

- Estimate the delay of a 10x inverter driving a 2x inverter at the end of the 5mm wire from the previous example.
 - $R = 2.5 \text{ k}\Omega \cdot \mu\text{m}$ for gates
 - Unit inverter: $0.36 \mu\text{m}$ nMOS, $0.72 \mu\text{m}$ pMOS

■ $t_{pd} =$

Wire RC Delay

- Estimate the delay of a 10x inverter driving a 2x inverter at the end of the 5mm wire from the previous example.
 - $R = 2.5 \text{ k}\Omega \cdot \mu\text{m}$ for gates
 - Unit inverter: $0.36 \mu\text{m}$ nMOS, $0.72 \mu\text{m}$ pMOS

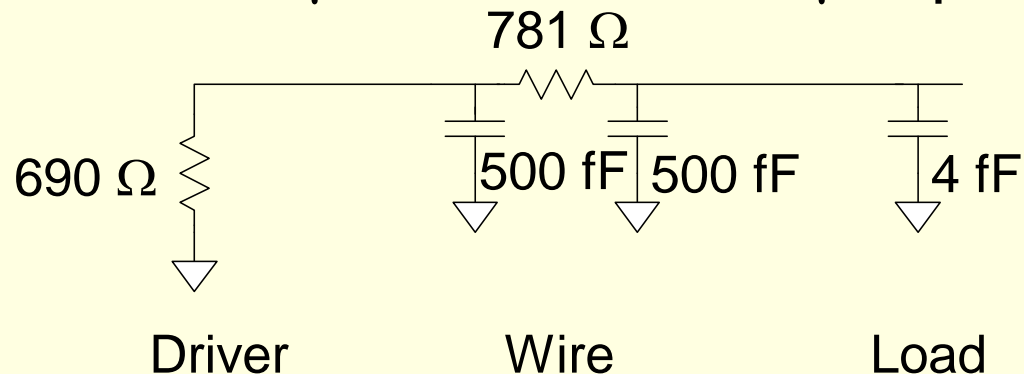

- $t_{pd} = 1.1 \text{ ns}$

Crosstalk

- A capacitor does not like to change its voltage instantaneously.
- A wire has high capacitance to its neighbor.
 - When the neighbor switches from 1-> 0 or 0->1, the wire tends to switch too.
 - Called capacitive *coupling* or *crosstalk*.
- Crosstalk effects
 - Noise on nonswitching wires
 - Increased delay on switching wires

Crosstalk Delay

- Assume layers above and below on average are quiet
 - Second terminal of capacitor can be ignored
 - Model as $C_{\text{gnd}} = C_{\text{top}} + C_{\text{bot}}$
- Effective C_{adj} depends on behavior of neighbors
 - *Miller effect*

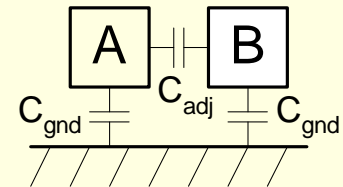

B	ΔV	$C_{\text{eff(A)}}$	MCF
Constant			
Switching with A			
Switching opposite A			

Crosstalk Delay

- Assume layers above and below on average are quiet
 - Second terminal of capacitor can be ignored
 - Model as $C_{\text{gnd}} = C_{\text{top}} + C_{\text{bot}}$
- Effective C_{adj} depends on behavior of neighbors
 - *Miller effect*

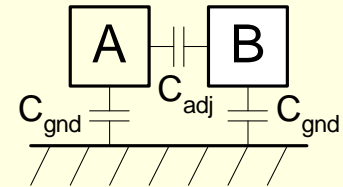

B	ΔV	$C_{\text{eff(A)}}$	MCF
Constant	V_{DD}	$C_{\text{gnd}} + C_{\text{adj}}$	1
Switching with A	0	C_{gnd}	0
Switching opposite A	$2V_{\text{DD}}$	$C_{\text{gnd}} + 2 C_{\text{adj}}$	2

Crosstalk Noise

- Crosstalk causes noise on nonswitching wires
- If victim is floating:
 - model as capacitive voltage divider

$$\Delta V_{victim} = \frac{C_{adj}}{C_{gnd-v} + C_{adj}} \Delta V_{aggressor}$$

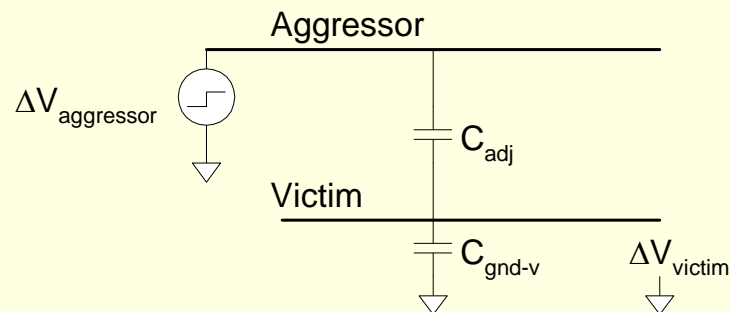

Driven Victims

- Usually victim is driven by a gate that fights noise
 - Noise depends on relative resistances
 - Victim driver is in linear region, agg. in saturation
 - If sizes are same, $R_{\text{aggressor}} = 2-4 \times R_{\text{victim}}$

$$\Delta V_{\text{victim}} = \frac{C_{\text{adj}}}{C_{\text{gnd-v}} + C_{\text{adj}}} \frac{1}{1+k} \Delta V_{\text{aggressor}}$$

$$k = \frac{\tau_{\text{aggressor}}}{\tau_{\text{victim}}} = \frac{R_{\text{aggressor}} (C_{\text{gnd-a}} + C_{\text{adj}})}{R_{\text{victim}} (C_{\text{gnd-v}} + C_{\text{adj}})}$$

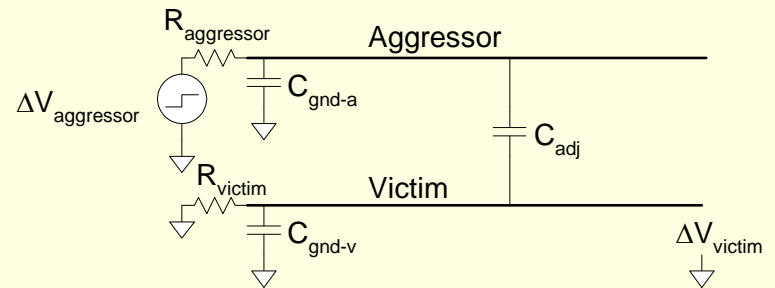

Coupling Waveforms

- Simulated coupling for $C_{adj} = C_{victim}$

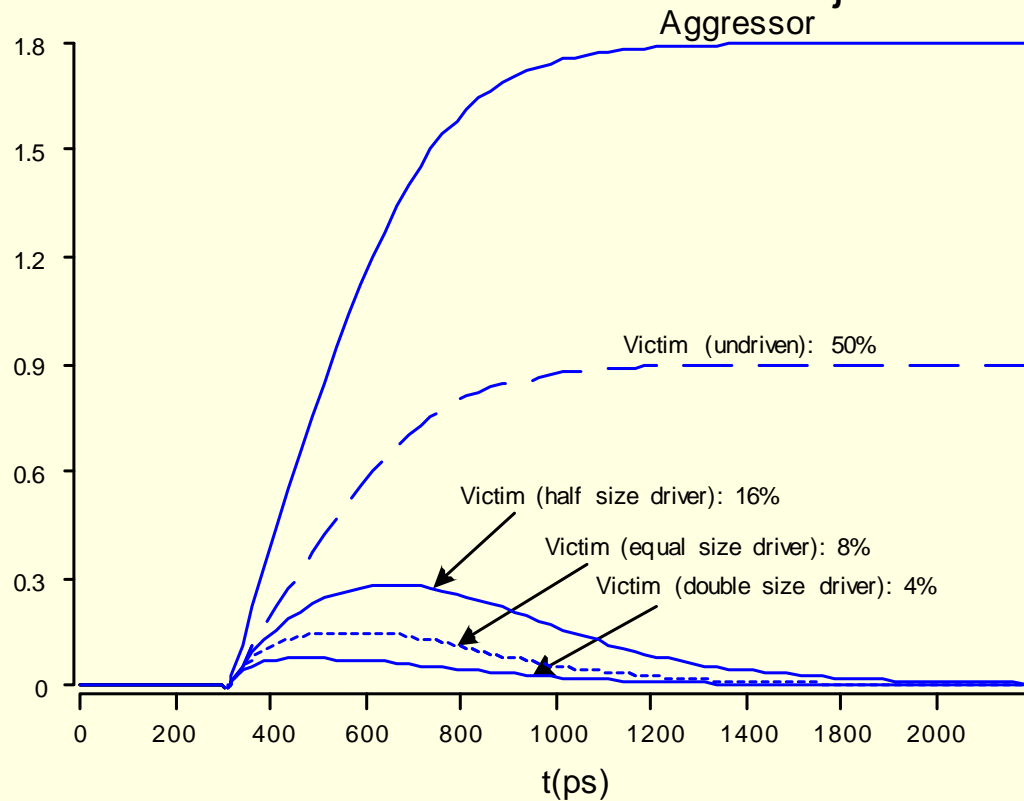

Noise Implications

- *So what if we have noise?*
- If the noise is less than the noise margin, nothing happens
- Static CMOS logic will eventually settle to correct output even if disturbed by large noise spikes
 - But glitches cause extra delay
 - Also cause extra power from false transitions
- Dynamic logic never recovers from glitches
- Memories and other sensitive circuits also can produce the wrong answer

Wire Engineering

- Goal: achieve delay, area, power goals with acceptable noise
- Degrees of freedom:

Wire Engineering

- Goal: achieve delay, area, power goals with acceptable noise
- Degrees of freedom:
 - Width
 - Spacing

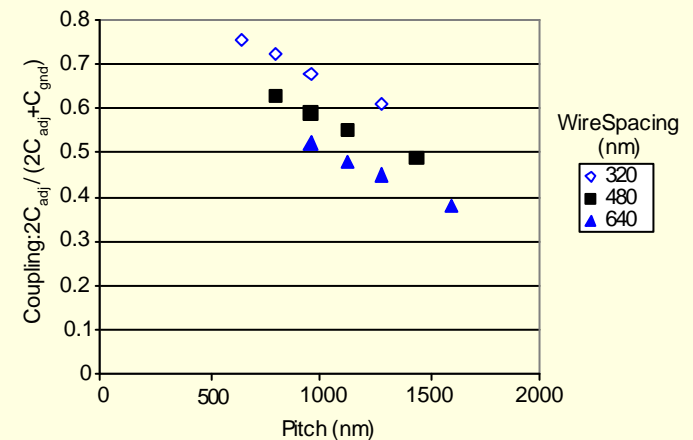
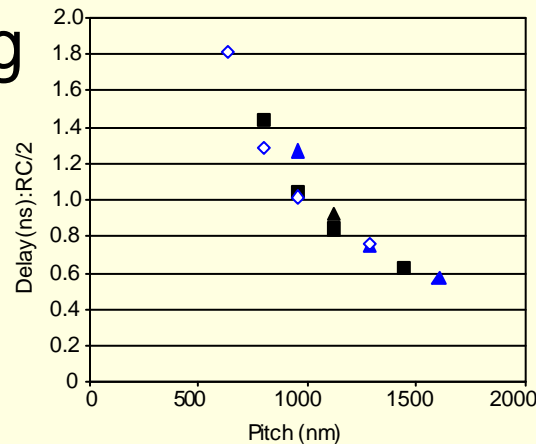

Wire Engineering

- Goal: achieve delay, area, power goals with acceptable noise
- Degrees of freedom:
 - Width
 - Spacing
 - Layer

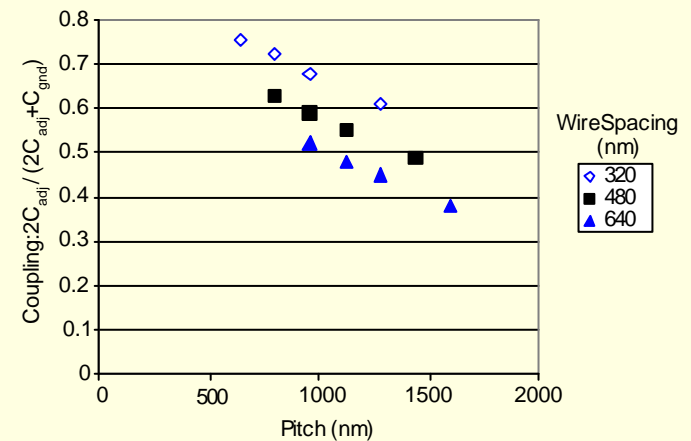
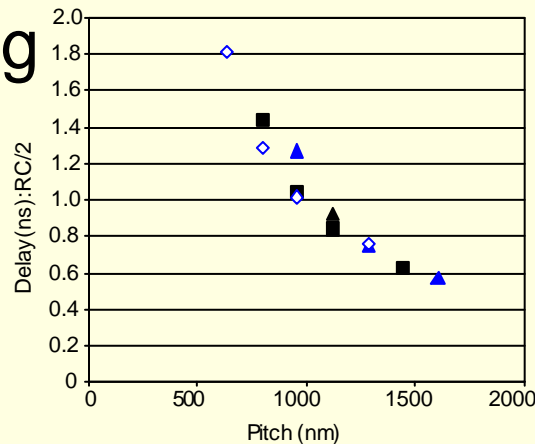

Wire Engineering

- Goal: achieve delay, area, power goals with acceptable noise
- Degrees of freedom:

- Width
- Spacing
- Layer
- Shielding

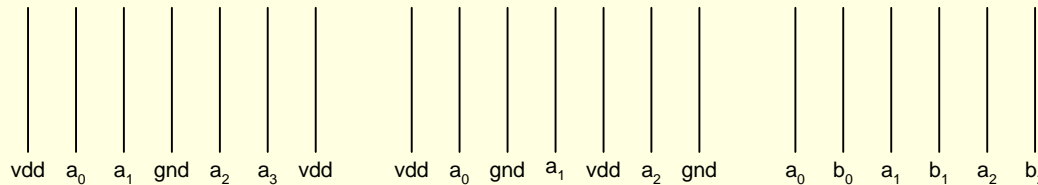
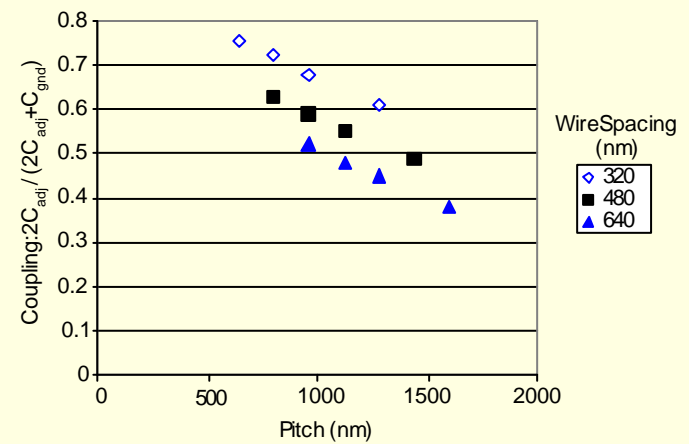
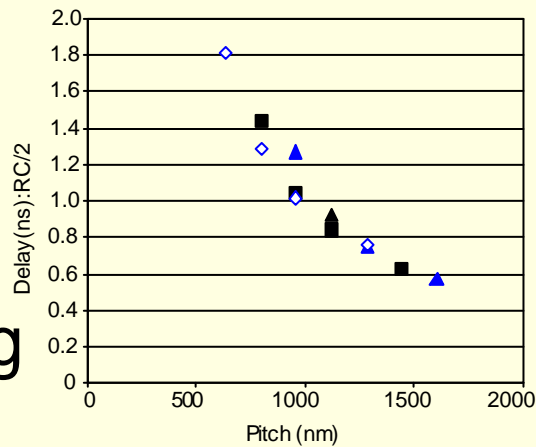

Repeaters

- R and C are proportional to l
- RC delay is proportional to l^2
 - Unacceptably great for long wires

Repeaters

- R and C are proportional to l
- RC delay is proportional to l^2
 - Unacceptably great for long wires
- Break long wires into N shorter segments
 - Drive each one with an inverter or buffer

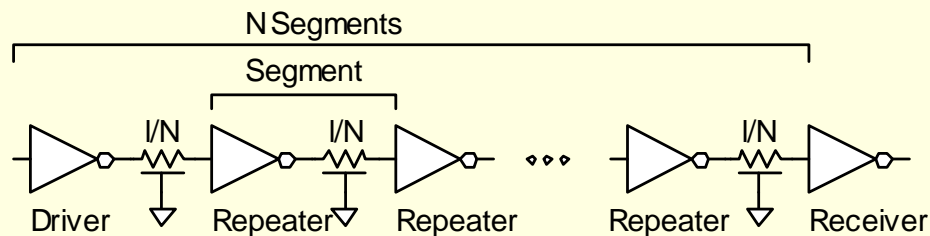
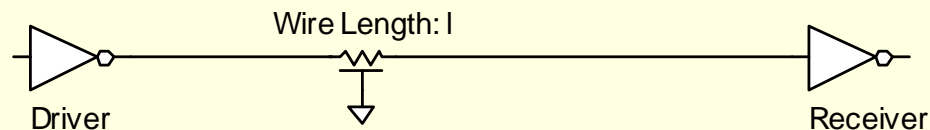

Repeater Design

- How many repeaters should we use?
- How large should each one be?
- Equivalent Circuit
 - Wire length l/N
 - Wire Capacitance $C_w * l/N$, Resistance $R_w * l/N$
 - Inverter width W (nMOS = W , pMOS = $2W$)
 - Gate Capacitance $C' * W$, Resistance R/W

Repeater Design

- How many repeaters should we use?
- How large should each one be?
- Equivalent Circuit
 - Wire length l
 - Wire Capacitance $C_w * l$, Resistance $R_w * l$
 - Inverter width W (nMOS = W , pMOS = $2W$)
 - Gate Capacitance $C' * W$, Resistance R/W

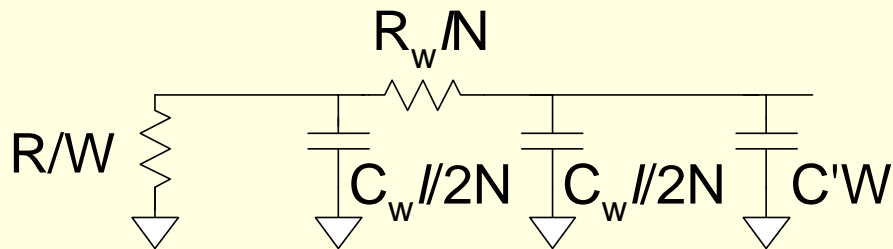

Repeater Results

- Write equation for Elmore Delay
 - Differentiate with respect to W and N
 - Set equal to 0, solve

$$\frac{l}{N} = \sqrt{\frac{2RC'}{R_w C_w}}$$

$$\frac{t_{pd}}{l} = (2 + \sqrt{2}) \sqrt{RC'R_w C_w}$$

~60-80 ps/mm

in 180 nm process

$$W = \sqrt{\frac{RC_w}{R_w C'}}$$